

Rubber expansion joints

General information

Rubber expansion joints are flexible rubber “bellows” made by vulcanizing of various rubber mixtures according to the parameters of the transported medium.

Pressure resistance is created by integrated reinforcement of nylon, polyester, Kevlar, glass fibers or reinforcement with steel mesh.

Pressure resistance of expansion joints in standard design is in nominal pressures PN 6, 10 and 16 bar at 20°C. Pressure resistance is designed by the supplier based on the type of expansion joint, bore size and operating temperature of the medium.

Rubber expansion joints are intended primarily for damping vibrations and noise from pumps and other vibrating aggregates and also for capturing thermal expansions in pipeline systems.

















Expansion joints are finished with rotating flanges, fixed flanges or with threaded fittings.

Expansion joints are supplied in bore sizes DN 15 to DN 4000.

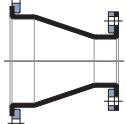
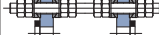

Material of rubber expansion joints

Marking	General heat resistance and use
EPDM	<ul style="list-style-type: none"> – operating temperature: –40°C up to +120°C – excellent aging, UV, ozone and weather-resistance – highly vapour resistant – highly soak-resistant and chemical-resistant to dilute acids, bases, acetone and alcohol – not suitable for aliphatic, aromatic or chlorinated hydrocarbons – standard blend: conductive with ATEX certificate – suitable for hot and cold water
EPDM beige	<ul style="list-style-type: none"> – food grade quality – non-conductive
EPDM tw	<ul style="list-style-type: none"> – for drinking water
EPDM af	<ul style="list-style-type: none"> – good wear resistancy
IIR	<ul style="list-style-type: none"> – operating tempaterure: –20°C up to +100°C – highly gas-tight – highly resistant to many dilute acids and bases – not very resistant to aliphatic, aromatic and chlorinated hydrocarbons
CSM	<ul style="list-style-type: none"> – operating temperature –20°C up to +100°C – excellent weather-resistance – favourable fire protection behaviour – very good to excellent resistance to oxidising chemicals – good oil resistance, including at high oil temperatures and resistance to many alloyed oils
NBR	<ul style="list-style-type: none"> – operating temperature –30°C up to +100°C – excellent soak-resistance against non-polar or slightly polar media, such as fuels – mineral oils, lubricants, plant and animal fats or oils – not resistant to esters, ketones, aromatic and chlorinated hydrocarbons
NBR beige	<ul style="list-style-type: none"> – suitable for food industry – non-conductive
CR	<ul style="list-style-type: none"> – operating temperature –20 up to +90°C – very good UV, ozone and weather-resistance – good flame resistance – adequate resistance to paraffinic, naphthenic and high molecular oils – chemical resistance to alkalis, diluted acids, aqueous salt solutions and reducing agents – not suitable for oxidising materials and concentrated mineral acids
NR	<ul style="list-style-type: none"> – operating temperature –20°C up to +70°C – satisfactory heat, aging and ozone resistance – high tensile strength at high elasticity up to 600% – very good abrasion resistance – not very resistant to hot water or steam – low soaking by aliphatics and other solvents – not resistant to chlorinated hydrocarbons, aromatics, esters and ketones
FPM	<ul style="list-style-type: none"> – operating temperature –20°C up to +180°C – excellent aging, UV, ozone and weather resistance – excellent general chemical resistance, also to hot oils, aliphatics, aromatics and chlorinated hydrocarbons – highly gas-tight – non-conductive
FPM beige	<ul style="list-style-type: none"> – food grade quality – non-conductive
Q (Silicon)	<ul style="list-style-type: none"> – operating tempaterure –60°C up to +200°C – excellent resistance to aging, UV, ozone and weather – very good radiation resistance – can be supplied for the food industry – should not be used for steam above +120°C – satisfactory resistance to engine and gear oils of aliphatic nature – not resistant to fuels, chlorinated hydrocarbons, esters, ketones or ether – highly susceptible to acids and bases – satisfactory gas tightness

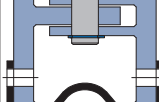











Expansion joints with fixed flanges type GKB

Type of expansion joint		Nominal diameter	Production lengths	Type of expansion joint		Nominal diameter	Production lengths
Type GKB100A 		DN 100 - DN 4000	L = 150 mm L = 200 mm L = 250 mm L = 300 mm L = 350 mm L = 400 mm	Type GKB900A 		based on individual request	based on individual request
Type GKB110A 		DN 100 - DN 4000	L = 150 mm L = 200 mm L = 250 mm L = 300 mm L = 350 mm L = 400 mm	Type GKB910A 		based on individual request	based on individual request
Type GKB120A 		DN 100 - DN 4000	L = 350 mm L = 400 mm L = 450 mm L = 500 mm L = 550 mm L = 600 mm	Type GKB100x 		DN 100 - DN 4000	L = 150 mm L = 200 mm L = 250 mm L = 300 mm L = 350 mm L = 400 mm
Type GKB130A 		DN 100 - DN 4000	L = 650 mm L = 850 mm L = 1050 mm	Type GKB110x 		DN 100 - DN 4000	L = 200 mm L = 250 mm L = 300 mm L = 350 mm L = 400 mm L = 450 mm L = 500 mm
Type GKB216A 		DN 100 - DN 4000	L = 250 mm L = 300 mm L = 350 mm	Type GKB120x 		DN 100 - DN 4000	L = 350 mm L = 400 mm L = 450 mm L = 500 mm L = 550 mm L = 600 mm L = 650 mm
Type GKB300A 		DN 80 - DN 1600		Type GKB216x 		DN 100 - DN 4000	L = 250 mm L = 300 mm L = 350 mm
Type GKB400A 		DN 300 - DN 4000	L = 250 mm L = 300 mm L = 350 mm	Type GKB110F 		DN 100 - DN 4000	L = 150 mm L = 200 mm L = 250 mm L = 300 mm L = 350 mm L = 400 mm











Expansion joints with flanges with threaded holes

Type of expansion joint		Nominal diameter	Production lengths
Typ GKA210A 		DN 32 up to DN 500	L = 100 mm L = 110 mm

Expansion joints with swivel flanges type GKA

Type of expansion joint		Nominal diameter	Production lengths	Type of expansion joint		Nominal diameter	Production lengths
Type GKA100A 		DN 40 to DN 1200	L = 150 mm L = 200 mm L = 250 mm L = 300 mm L = 350 mm L = 400 mm	Type GKA C10 		DN 25 to DN 1200	L = 95 mm (DN 25 – 40) L = 105 mm (DN 50) L = 115 mm (DN 65) L = 130 mm (DN 80) L = 135 mm (DN 100) L = 170 mm (DN 125) L = 180 mm (DN 150) L = 205 mm (DN 200) L = 240 mm (DN 250) L = 260 mm (DN 300) L = 265 mm (DN 350 – DN 1200 mm)
Type GKA C15 		DN 25 to DN 300	L = 130 mm	Type GKA110A 		DN 20 to DN 1200	L = 130 mm L = 150 mm L = 175 mm L = 200 mm L = 250 mm L = 275 mm L = 300 mm L = 350 mm
Type GKA C10R 		DN 25 to DN 600	L = 150 mm (to DN 200) L = 200 mm (from DN 250 - DN 500) L = 250 mm (DN 600)	Type GKA120A 		DN 200 to DN 1200	L = 350 mm L = 400 mm L = 450 mm L = 500 mm L = 550 mm L = 600 mm







Expansion joints for clamp fixing type GKS

Type of expansion joint		Nominal diameter	Production lengths	Type of expansion joint		Nominal diameter	Production lengths
Type GKS100 		DN 50 to DN 4000	L = 125 mm L = 150 mm L = 175 mm L = 200 mm L = 225 mm L = 250 mm	Type GKS130 		DN 50 to DN 4000	L = 600 mm L = 800 mm L = 1000 mm
Type GKS110 		DN 50 to DN 4000	L = 125 mm L = 150 mm L = 175 mm L = 200 mm L = 225 mm L = 250 mm	Type GKS300 		DN 50 to DN 4000	L = assembly gap + 2 x standard mounting gap, is from L = 75 mm do L = 2100 mm
Type GKS120 		DN 50 to DN 4000	L = 250 mm L = 300 mm L = 350 mm L = 400 mm L = 450 mm L = 500 mm				

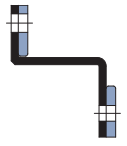

Expansion joints with threaded fitting type GKZ

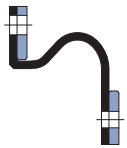
Type of expansion joint		Nominal diameter	Production lengths
Type GKZ TF30 		DN 15 to DN 80	L = 200 mm (from DN 15 to DN 50) L = 240 mm (from DN 65 to DN 80)

Wall seals type GWK

Type of expansion joint		Nominal diameter	Production lengths	Type of expansion joint		Nominal diameter	Production lengths
Type GWK100x 		DN 200 to DN 4000	L = 150 mm L = 200 mm L = 250 mm	Type GWK200x 		DN 50 to DN 1000	L = 60 mm
Type GWK110x 				Type GWK300x 			

Special expansion joints

Type of expansion joint		Nominal diameter	Production lengths	Type of expansion joint		Nominal diameter	Production lengths
Dog Bone 		based on individual request	based on individual request	Elbow 		based on individual request	based on individual request

Tie rod designs

To absorb the axial reaction forces of the expansion joints and to define the size and direction of movement, it is possible to supply expansion joints with a tie rod system. We recommend using tie rods if the pipe layout does not ensure the absorption of the axial reaction force of the expansion joint. Depending on the requirements, the following tie rod designs are used:

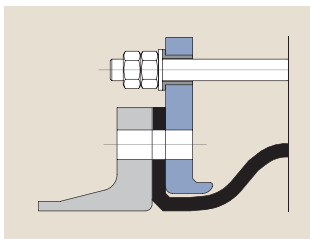

Type B
Tie rods mounted from the outside in rubber bushing to accommodate reaction force in the event of pressure (up to DN 300).

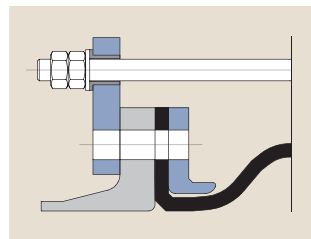

Type R
Control unit plates: Tie rods mounted from the outside in the rubber bushing to accommodate reaction forces in the event of pressure (up to DN 300).

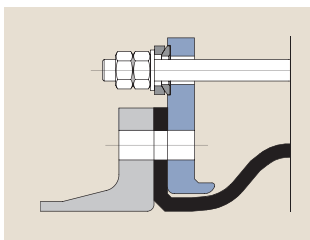

Type E
Tie rods mounted from the outside in spherical bearings and ball disks to accommodate the reaction force in the event of pressure.

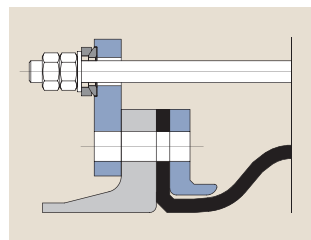

Type K
Control unit plates: Tie rods mounted from the outside in spherical bearings and ball disks to accommodate reaction forces in the event of pressure.

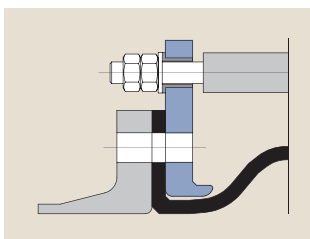

Type C
Tie rods mounted from the outside in rubber bushing and inside in the thrust limiter to accommodate stresses in the event of pressure or vacuum (up to DN 300).

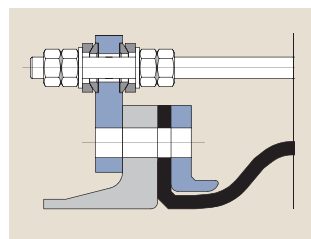

Type L
Control unit plates: Tie rods mounted from the outside and inside in spherical bearings and ball disks to accommodate reaction forces in the event of pressure and vacuum.

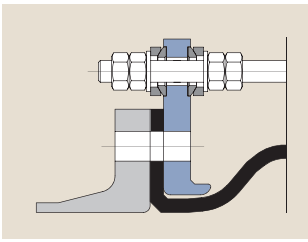

Type M
Tie rods mounted from the outside and inside in spherical bearings and ball disks to accommodate the reaction forces in the event of pressure and vacuum. Designed exclusively for lateral movements.

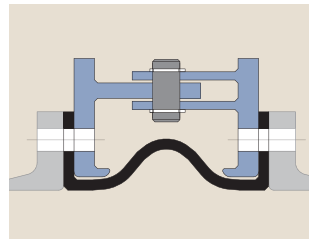

Type F
Hinge tie rods: For angular movements on one level with plates and bolts to accommodate the reaction force in the event of pressure and vacuum. Axis of rotation in the middle of the installation gap.

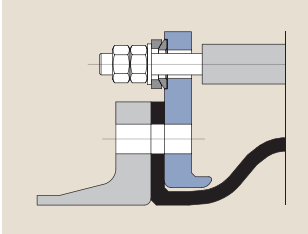

Type S
Tie rods mounted from the outside in spherical bearings and ball disks, as well as internally in thrust limiters to accommodate stresses in the event of pressure and vacuum.

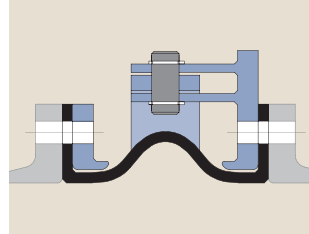

Type G
Cardan joint tie rods: For angular movements on two levels with plates and bolts to accommodate the stresses in the event of pressure and vacuum. Axes of rotation in the middle of the installation gap.

Vacuum and pressure reinforcing ring

Rubber expansion joints can be equipped with an internal vacuum reinforcement spiral, a vacuum reinforcement ring and/or an external pressure reinforcement ring to protect against deformation of the rubber bellows due to operating pressure or vacuum. Reinforcement rings cause a reduction in the displacement of the rubber expansion joints. In case of contact with the medium, it is necessary to check the resistance of the reinforcement ring material.

Design		Vacuum support ring	Pressure support ring	Pressure
With internal vacuum support ring		Medium contact, inside the arch apex	without	Depending on the nominal diameter up to 25 bar, for vacuum up to 0,05 bar absolute
With embedded vacuum support ring		No medium contact, embedded into the arch apex of the rubber bellows	without	Depending on the nominal diameter up to 25 bar, for vacuum up to 0,05 bar absolute
No vacuum ring, with pressure support ring in the arch trough		without	External in the arch trough	Depending on the nominal diameter up to 25 bar, slight vacuum
With internal vacuum support ring and external pressure support ring in the arch trough		Medium contact, inside the arch apex	External in the arch trough	Depending on the nominal diameter up to 25 bar, for vacuum up to 0,05 bar absolute
With embedded vacuum support ring and external pressure support ring in the arch trough		No medium contact, embedded into the arch apex of the rubber bellows	External in the arch trough	Depending on the nominal diameter up to 25 bar, for vacuum up to 0,05 bar absolute.
With embedded support rings in the arch foot		No medium contact, embedded into the arch foot of the rubber bellows.		Depending on the nominal diameter up to 25 bar, for vacuum up to 0,05 bar absolute

Other additional design elements

- steel flow protection liner
 - in case of transporting abrasive media
 - if the medium flow rate is higher than 5 m/s

Conical flow liner

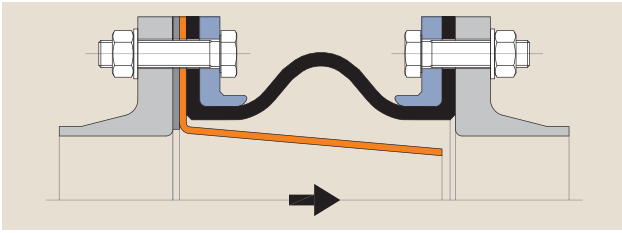

Telescopic flow liner

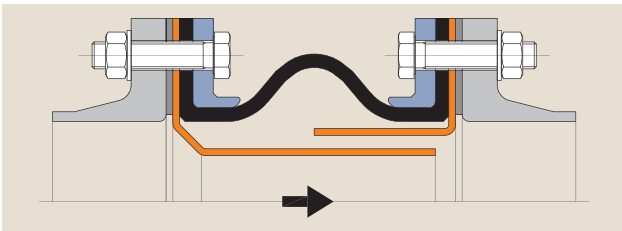

Flow liner with a centring flange

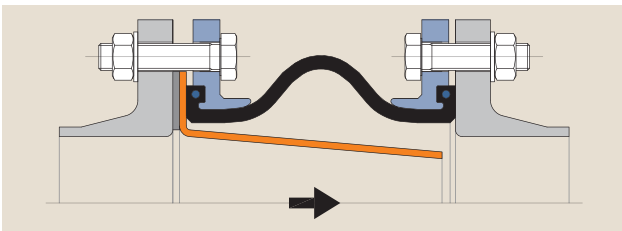

- external protective hoods / covers for expansion joints
 - protection against mechanical damage
 - protection against UV (pict. 1A)
 - protection against radiant heat
 - increased operator safety in the event of a leak (pict. 1B)

pict. 1A

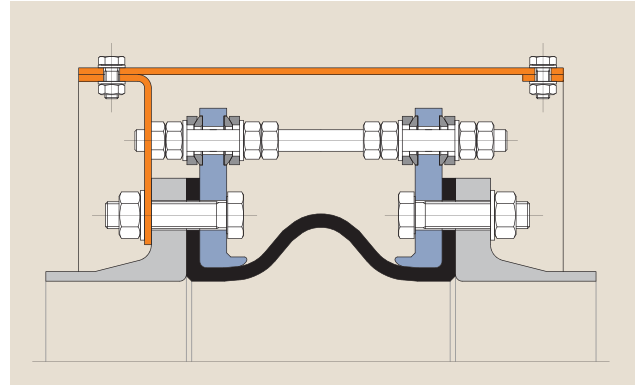

pict. 1B

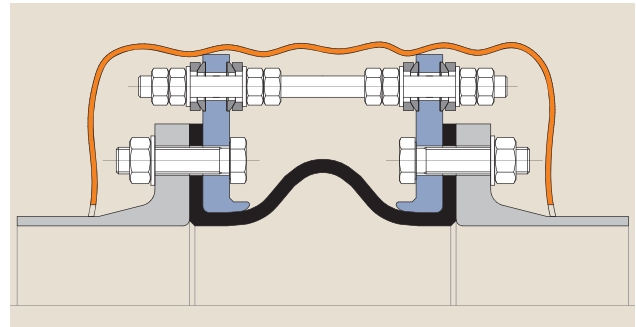

Correct / incorrect installation of rubber expansion joints

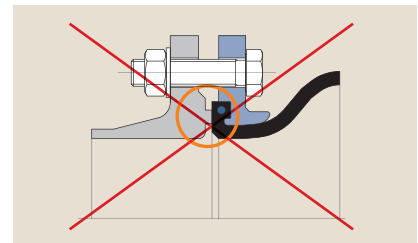
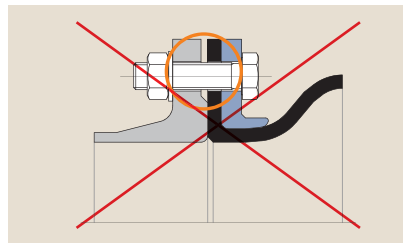
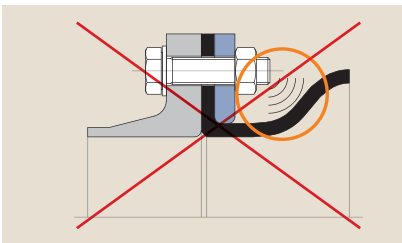
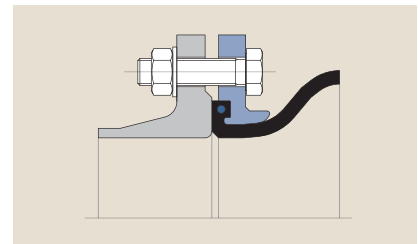
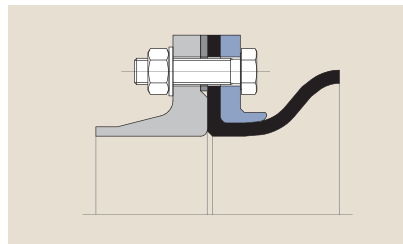
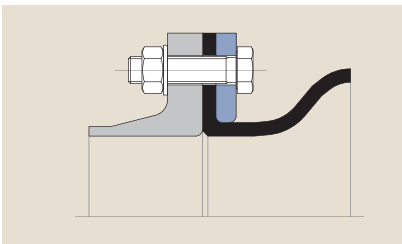

Specification requirements for rubber expansion joints

- medium, temperature of medium, working / test pressure
- requirements for type/size of movements/vibrations
- You can find the expansion joint questionnaire on our website www.kohaflex.sk/sk/dotaznik/dotaznik-na-specifikaciu-kompzatorov/



Company KOHAFLEX holds a Quality Management Certificate ISO 9001

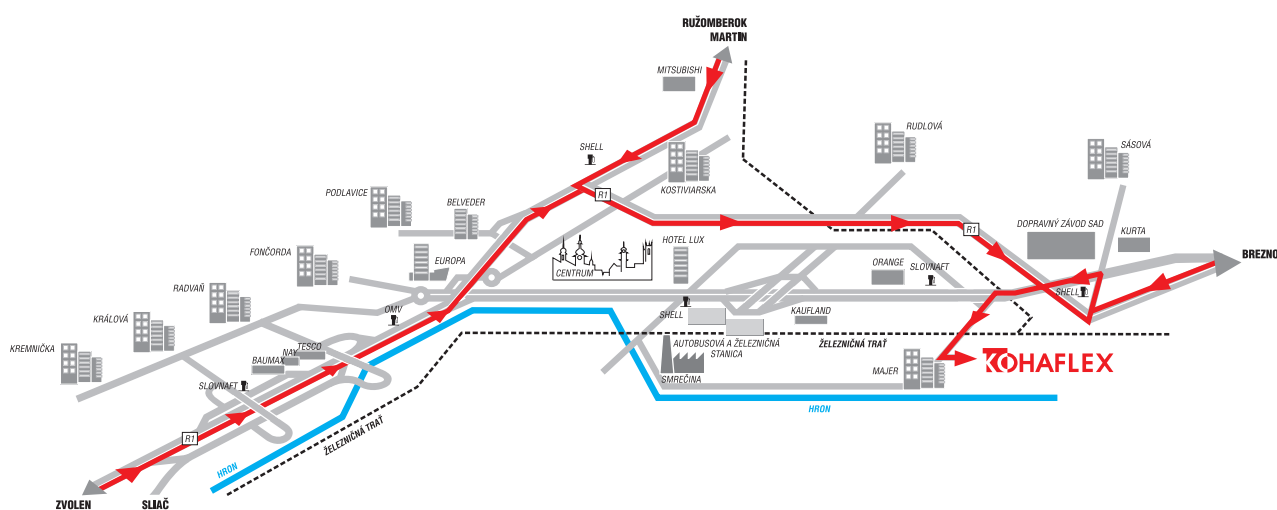

KOHAFLEX spol. s r. o.
 Majerská cesta 57, 974 01 Banská Bystrica
 tel.: 00421 48 414 89 57, 00421 48 414 89 58
 e-mail: kohaflex@kohaflex.sk
 www.kohaflex.sk

KOHAFLEX CZ spol. s r. o.
 Kotkova 6, 703 00 Ostrava – Vítkovice
 tel./fax: 00420 602726584, 00420 602117790
 e-mail: kohaflex@kohaflex.cz
 www.kohaflex.cz